



The EGU and EGUU are intended for outdoor wall mounting.

The EGUU contains two separate thermistors for

connection to different kinds of controller units or for mean value measurement.

The body has a hole  $\varnothing 19$  for cable fitting Pr 18,6.

## TECHNICAL SPECIFICATION

**Part number:**

EGU .....	514-1100-000
EGUU .....	514-2200-000
Operating temperature .....	-40 – +90 °C
Time constant .....	12 minutes (0,5 m/s) 20 minutes (0,1 m/s)
Accuracy .....	$\pm 0,6$ °C at 25 °C
Enclosure rating .....	IP 54
<b>Material:</b>	
Body .....	carbonate plastic, red
Cap .....	carbonate plastic, black
Housing .....	ABS plastic, beige
Weight .....	140 g

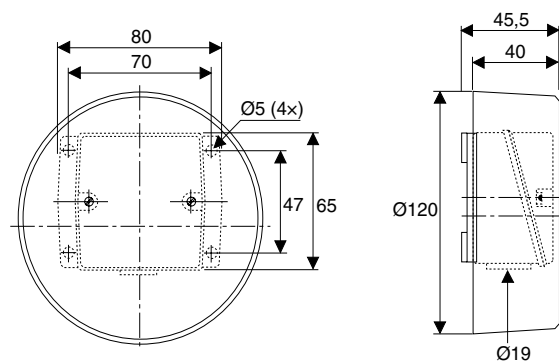

## WIRING DIAGRAM

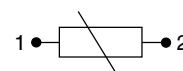

EGU

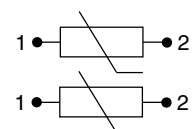

EGUU